

DVS-Filtertechniek B.V.  
Wiebachstraat 41  
6466NG Kerkrade  
The Netherlands  
[www.dvs-filtertechniek.com](http://www.dvs-filtertechniek.com)  
[info@dvs-filtertechniek.com](mailto:info@dvs-filtertechniek.com)

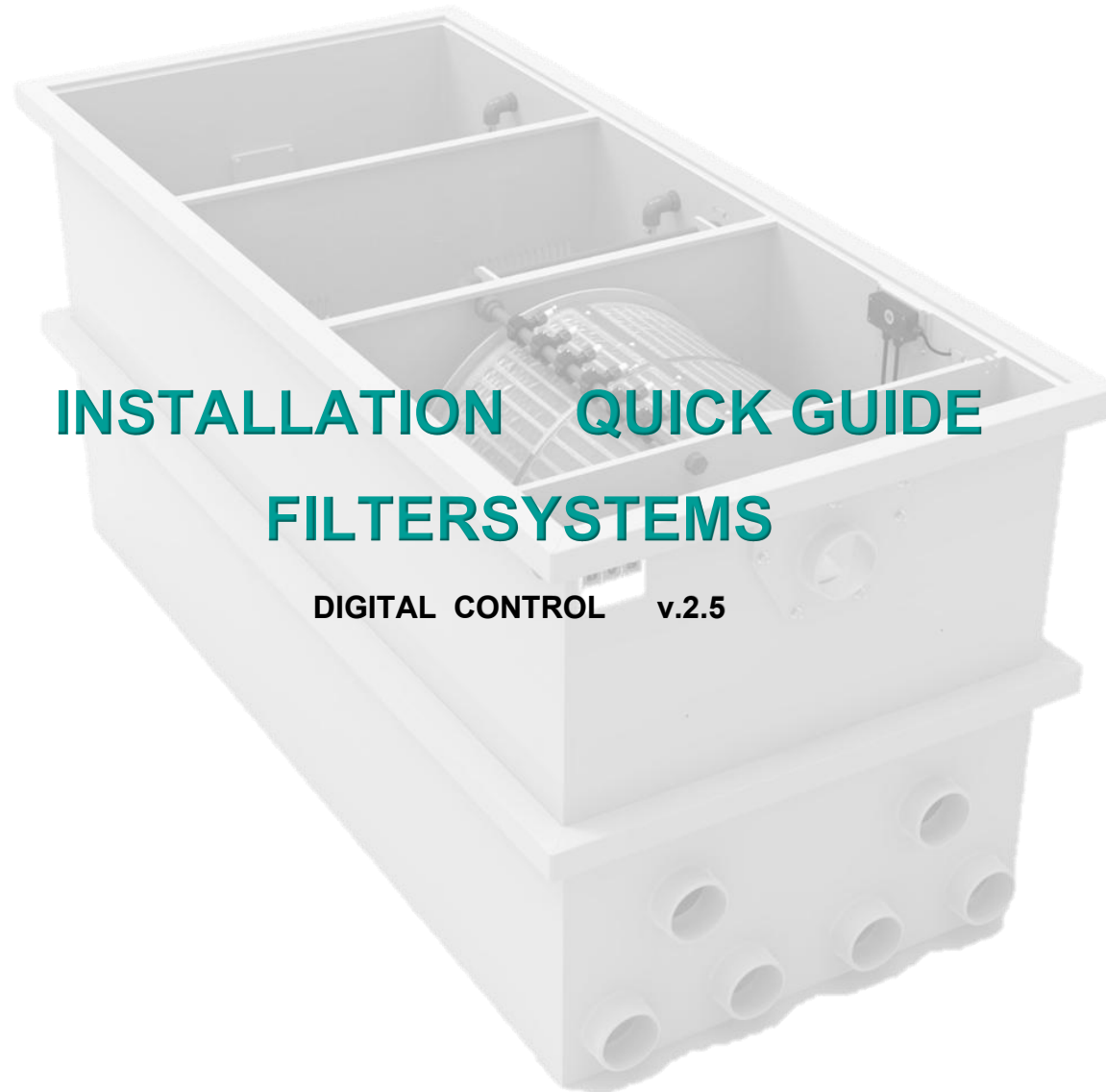

# INSTALLATION QUICK GUIDE

## FILTERSYSTEMS

DIGITAL CONTROL v.2.5



## Index

<b>1</b>	<b>SAFETY</b> .....	<b>3</b>
1.1	Symbols .....	3
1.2	Warnings / safety regulations .....	3
<b>2</b>	<b>BASIC REQUIREMENTS</b> .....	<b>4</b>
2.1	Control unit.....	5
2.2	Configuration .....	6
2.3	Options.....	7
<b>3</b>	<b>A. GRAVITY SYSTEM</b> .....	<b>8</b>
3.1	Placing the filter system .....	8
3.2	Schematic setup.....	9
3.3	Set level control.....	9
<b>4</b>	<b>B. PUMP FED SYSTEM</b> .....	<b>11</b>
4.1	Placing the filter system .....	11
4.2	Schematic setup.....	11
4.3	Set level control .....	11
<b>5</b>	<b>POND REFILL SYSTEM</b> .....	<b>13</b>
<b>6</b>	<b>TROUBLESHOOTING</b> .....	<b>14</b>
<b>7</b>	<b>MAINTENANCE SCHEDULE</b> .....	<b>15</b>

## 1 SAFETY

### 1.1 Symbols

The following symbols are fixed to the filter.



*Warning of dangerous electrical voltage.*



*Use safety glasses when spray head is enabled.*

### 1.2 Warnings / safety regulations



*During assembly or maintenance work, disconnect the device from the power supply.*

- Make sure there is no damage to the filter before connecting it. Check the power cords and plugs carefully before connecting.
- It is forbidden to use the machine for other uses as intended by the manufacturer. Unintended use can lead to unforeseeable risks.

- **PAY ATTENTION ROTATING PARTS !**

Safety devices, such as protective covers/safety circuits, must never be removed or bypassed during normal use of the device.

The fixed separations on the gear drive have been attached with fastenings such as bolts. These features prevent any contact with moving parts and therefore protect from severe injury.

The removal of fixed guards, or the operation of the machine without any of these guards is not allowed!

Immediately after the execution of this work, the safety devices must be installed / activated again and checked for their functionality.

For this, only the original mounting hardware of the safety devices can be (re)used.

- Never try to stop the rotating drum with your hands.
- The motor and all electrical connections must not come in contact with water. If this does happen, make sure everything is dry before switching the filter back on.
- The controller of the drum filter may only be connected to an earthed socket.

**ELECTRICAL WIRING AND/OR PLUGS MUST NOT BE CUT. THIS IMMEDIATELY voids THE MANUFACTURER'S WARRANTY EN LIABILITY.**

## 2 BASIC REQUIREMENTS

Basic requirements every filter system must meet:

- The filter system should be placed on a ground surface with sufficient carrying capacity, for instance:
  - a well-vibrated sand bed of 10 cm, possibly with concrete tiles
  - a concrete floor

In the event of subsidence, the filter may not function properly!

- The filter system should be placed fully level.
- Leave sufficient space around the filter, to perform cleaning and maintenance work.
- The filter control should be in a dry area, preferably indoors.
- The drive motor is splash-proof, so it should not be left in the rain.
- The filter may be flushed max. 5x per hour. If the filter is flushed more often, the lifespan of the engine will be drastically reduced.

The filter system can be used as gravity-system or pump fed system.



**IMPORTANT!**

*The correct placement and constant water level in the pond are important conditions for optimal and problem-free operation of the filter system.*



**IMPORTANT!**

*The use of salt in the pond can cause stainless steel components of the filter to oxidize.*

2.1 Control unit 

Controller is not waterproof, please keep it out of the water! Place it under cover from the rain and wind.



**CAUTION!**  
Insert the correct plug into the correct socket. Inserting the wrong plug into a socket can blow the fuse due to excessive current.



Manual cleaning:  
Press and hold this button  
to flush manually

Power switch  
(Emergency switch)

Socket  
motor drum filter  
**Max. 200W**

Socket  
sensor

PLEASE NOTE: if this is not  
connected, there will be no power  
to the circulation pump socket.

Socket  
cleaning pump  
**Max. 800W**

Socket  
Circulation pump (**max. 1 pcs / max. 1150W**)

If you want to connect more than one  
pond pump, you must use a power switch.  
Art. 550.2506 - Power switch 25 Ampere

## 2.2 Configuration

Log in to the WiFi module:  
 Look for new networks:  
 Password:

DVS FILT  
 Welkom123456

Go to the internet browser,  
 log in at the following address:

192.168.1.1

### Dip switch

- 1 on → gravity
- 1 off → pump fed
- 2 on → sensor 2-pens

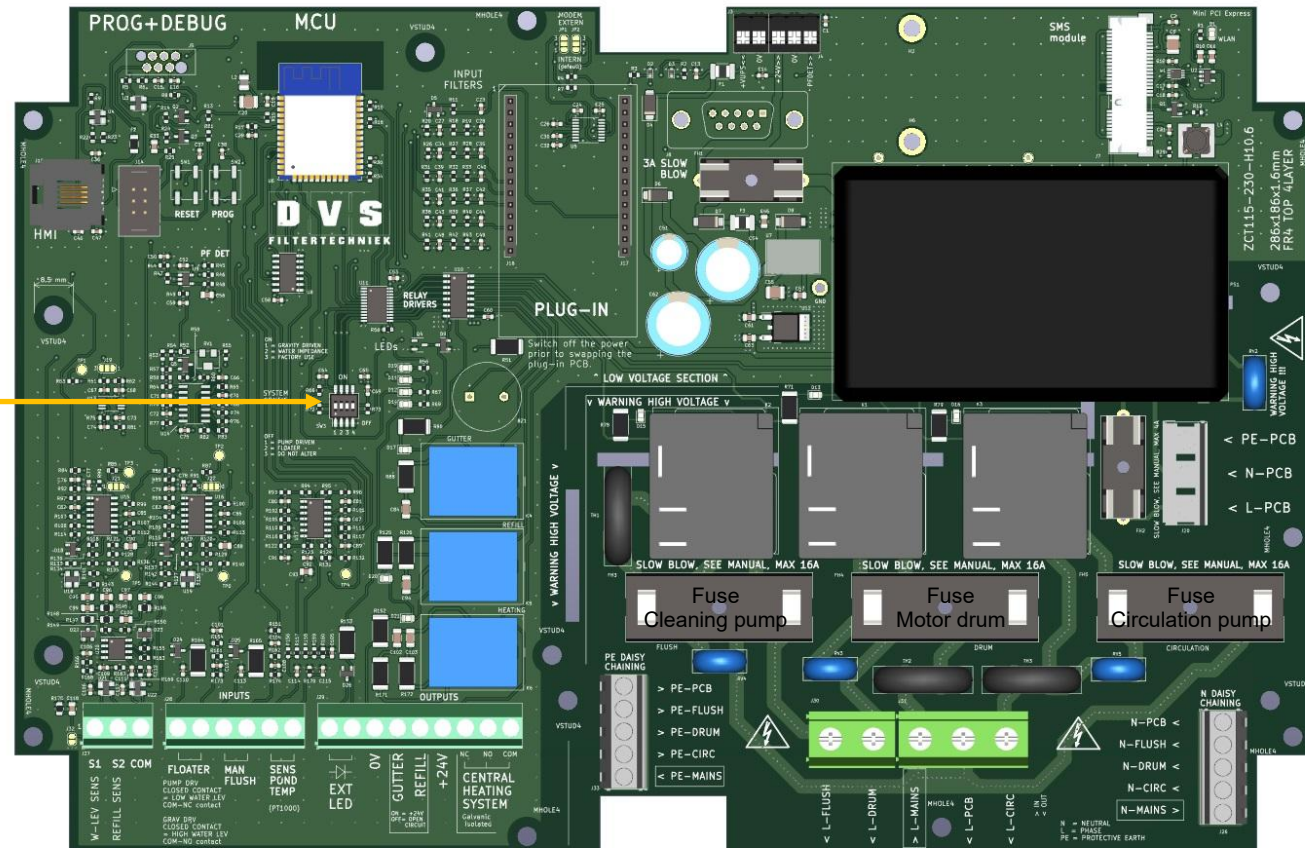
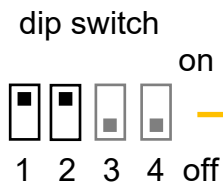

### Fuses

Cleaning pump	6A
Motor drum	2A
Circulation pump	8A

2.3 Options

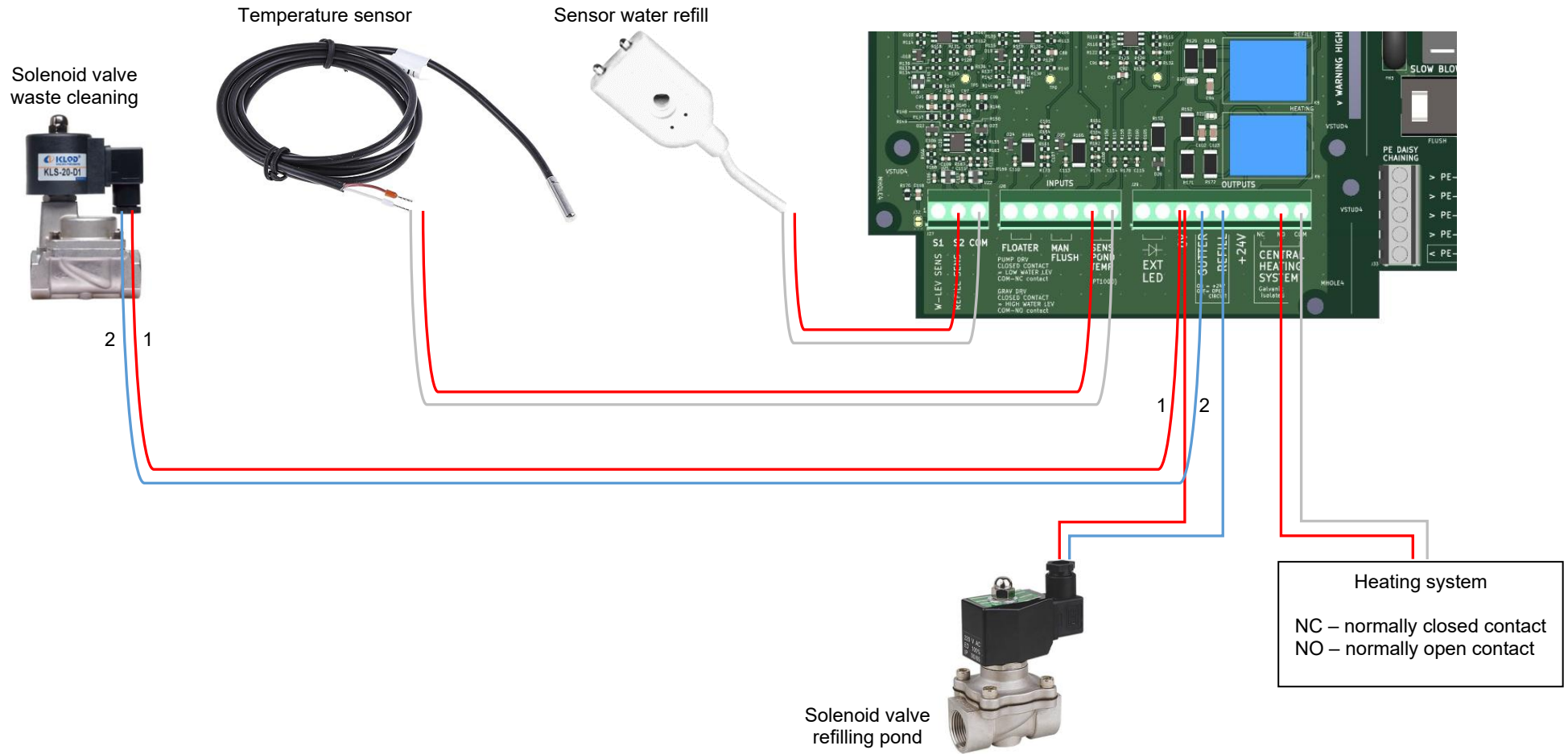

### 3 A. GRAVITY SYSTEM

#### 3.1 *Placing the filter system*

- Determine the maximum water level of the pond.
- Align the base plate horizontally (the filter should be placed fully level).
- The filter should be placed the height of the installation height (pic. 2.1) above water level.  
(installation height is the distance from maximum water level to top of filter).
- For the operation of the gravity system a constant water level in the pond is necessary.  
A tolerance of up to 20 mm below maximum water level is allowed.
- Should the maximum water level in the pond exceed this, the excess water will be disposed of via the waste water drain, until the maximum water level has been reached.

Type filter	Installation height [cm]
ENTRY25	16
ECO15	16
ECO22	16
D50	12
PP22	17
PP35	17
PP35-P	12
PP50	12
PP50-P	12
PP65	12
PP65-P	12
PP100N	12
PP140N	12
ENTRY C25	17
ENTRY M25	17
C15	12
C22	12
C35-M	12
C65-M	12
CL15	12
CL22	12
CL35 (K/L/M)	12
CL50 (K/L/M)	12
CL65 (K/L/M)	12

### 3.2 Schematic setup

To get the best out of the drum filter, use all of the water inlets. This result in good water turn over ratio for your pond.

### 3.3 Set level control

Sensor / float switch in clean chamber.

Pic. 3.2 / 3.3

1. Water level with running pump after rinse (8 cm above upper float switch)
2. Start rinsing  
Dry run time at set time

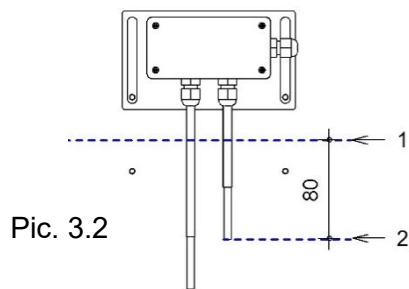

Pic. 3.2

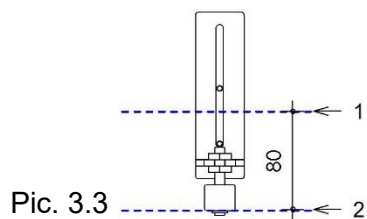

Pic. 3.3

- For Gravity, the water level of the pond must lined with the top of the drum filter waste tray.
- The water outlets on the top of the drum filter must be closed as these outlets are for pump fed usage configuration.
- The return pump is determined by how much water flow from the pond to the drum filter. For example if you have 20.000 L water flow from pond to drum filter, but you are using 50.000 L pump to push water from drum filter to shower or back to pond. This would not work, as you are missing 30.000 L. The flow must be balanced.

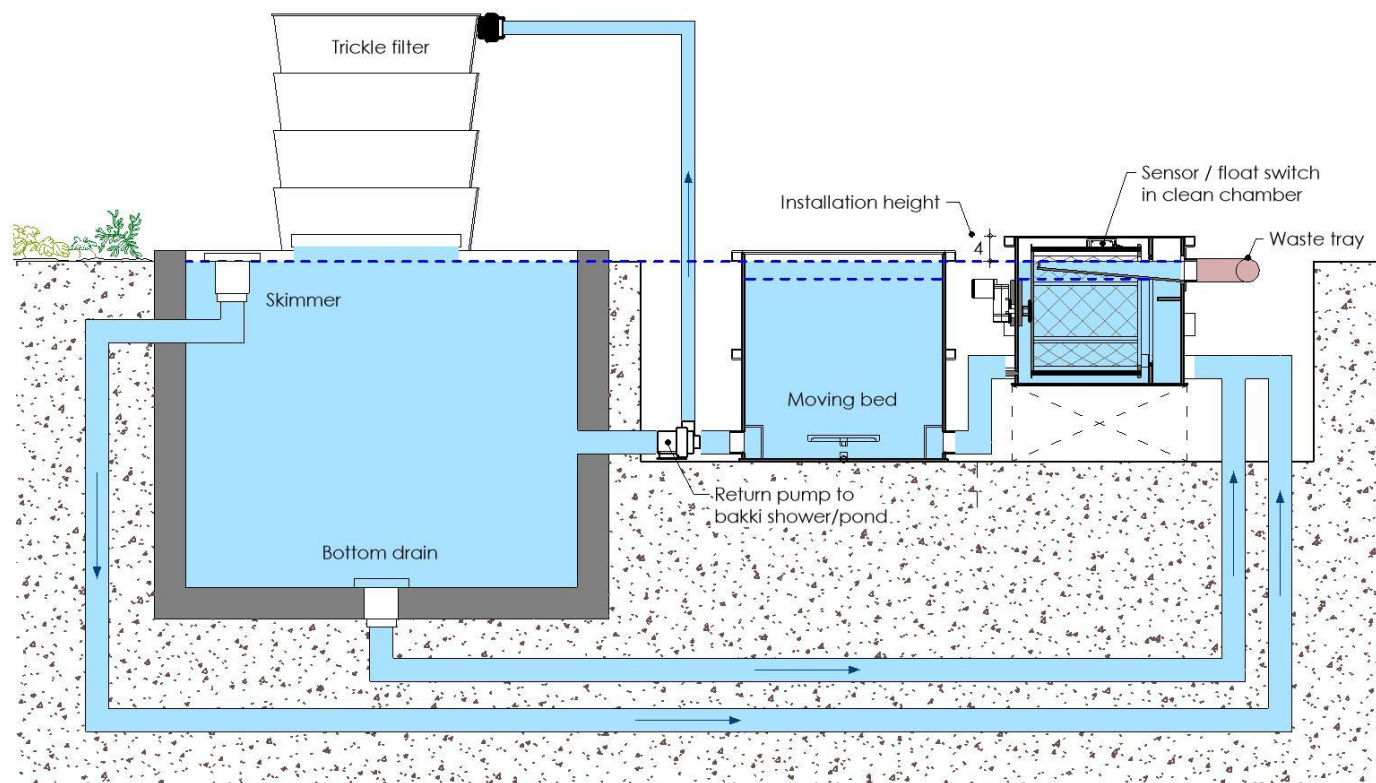

Pic. 3.1 Schematic setup of the drum filter

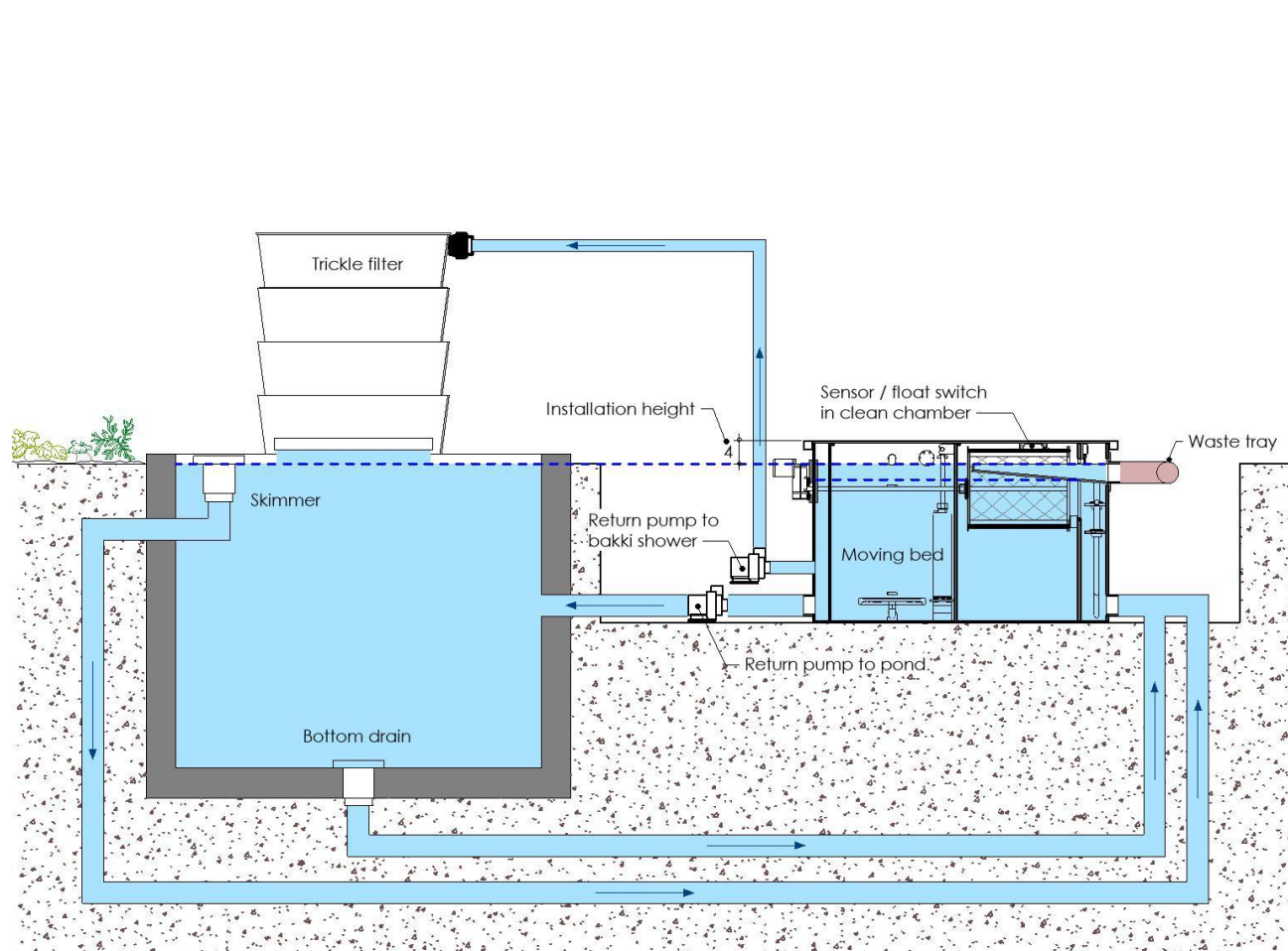

Pic. 3.4 Schematic setup of the combi filter

## 4 B. PUMP FED SYSTEM

### 4.1 Placing the filter system

- The filter system should be placed fully level.
- The filter should be 20 cm higher than the bio chamber (top of edge see pic. 4.1)
- Install a tee at the outlets help prevent air pressure build up and help with steady water out flow

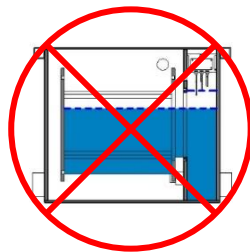

### 4.2 Schematic setup

- For Pump fed, you can use a water pump to push water from the pond/skimmer into the drum filter and from the drum filter the water gravity flow back to the bio chamber, however the drum filter unit must be above these unit.
- For Pump fed, close all the bottom outlets and use the high placed outlets. Do not use the bottom outlets as the water level would be too low inside the screen chamber as result this would put a lot of pressure on the screen.

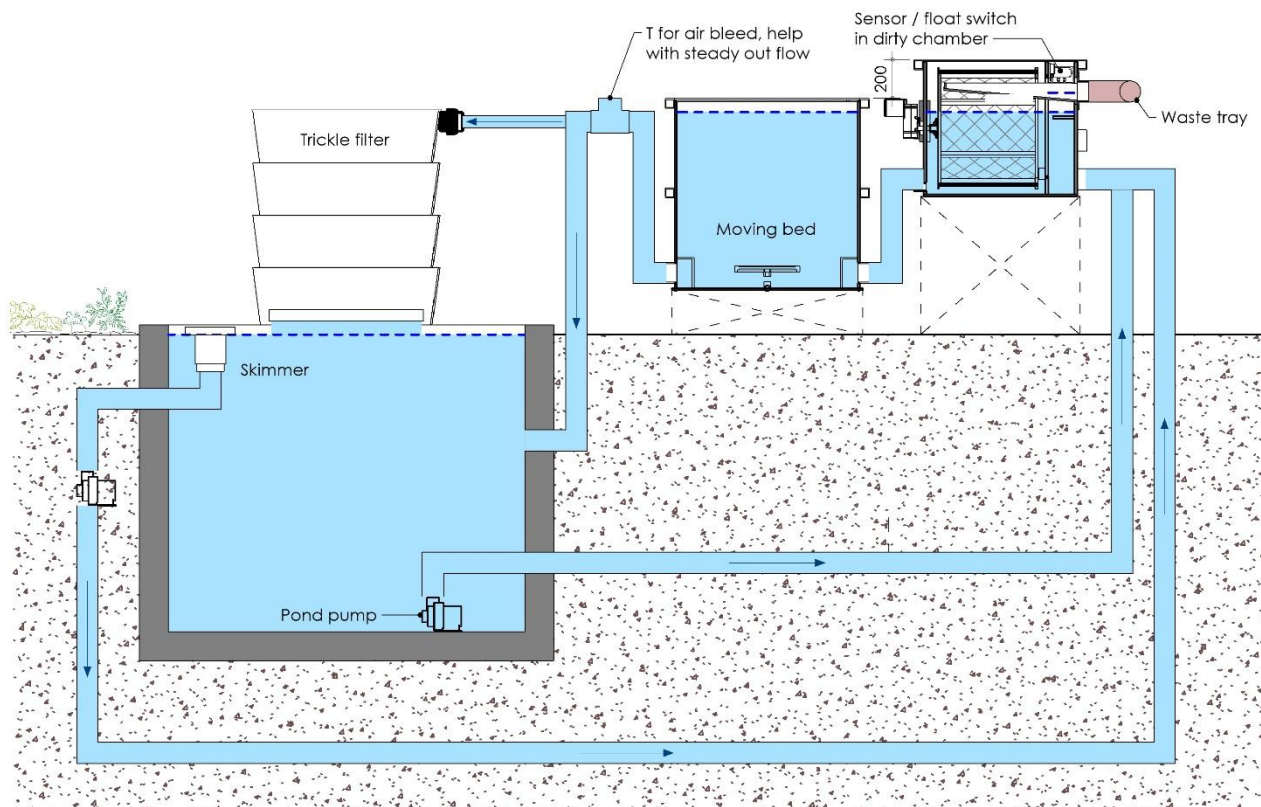

Pic. 4.1 Schematic setup of the drum filter

### 4.3 Set level control

Sensor / float switch in dirty chamber.

Pic. 4.2 / 4.3

1. Water level with running pump after rinse
2. Start rinsing & Dry run time at set time

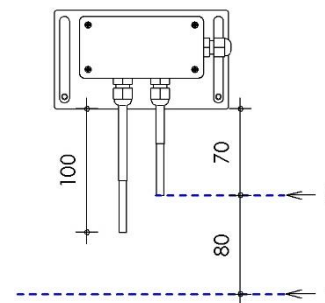

Pic. 4.2

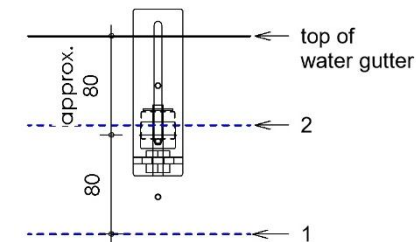

Pic. 4.3

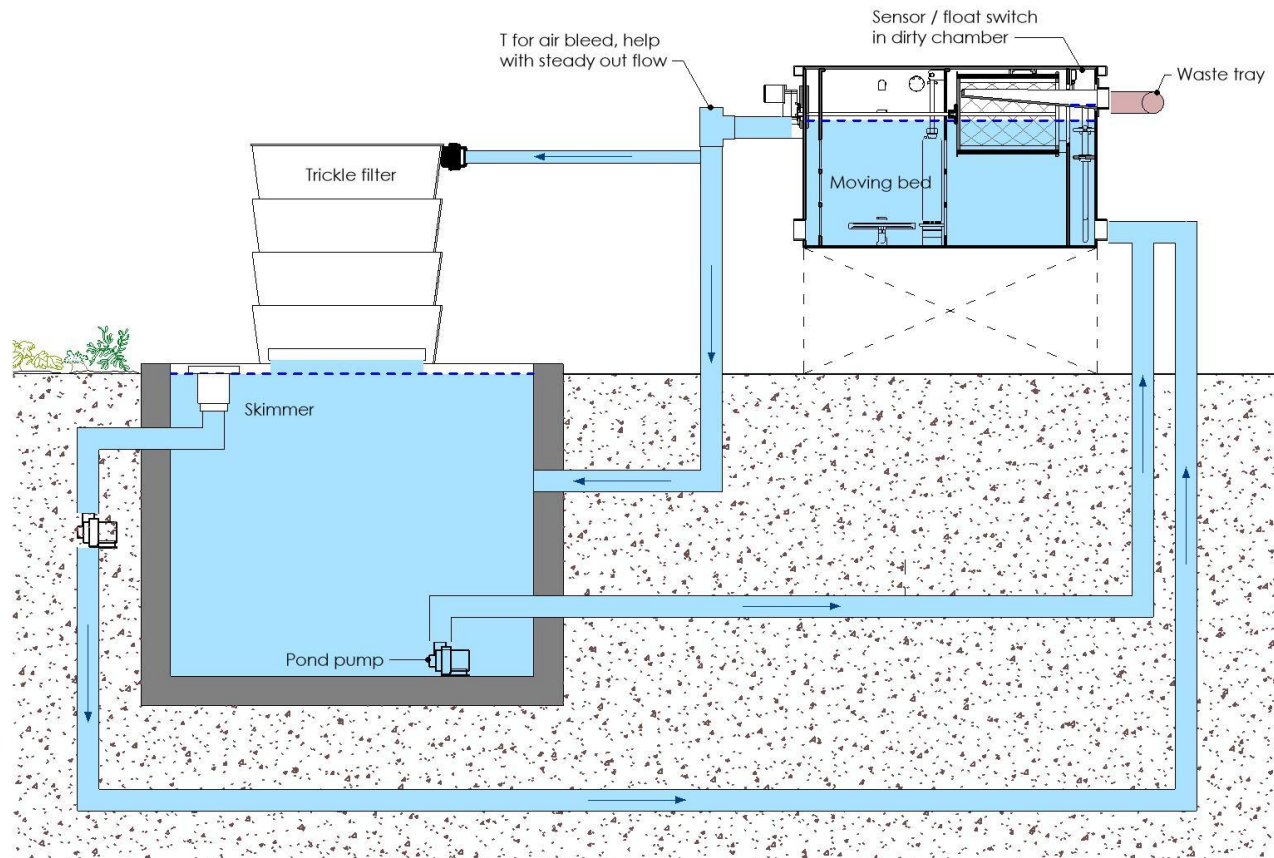

Pic. 4.4 Schematic setup of the combi filter

## 5 POND REFILL SYSTEM

Our advice is to use an automatic refill system, to ensure the water level remains constant. (See also chapter 3.4 dot 4).

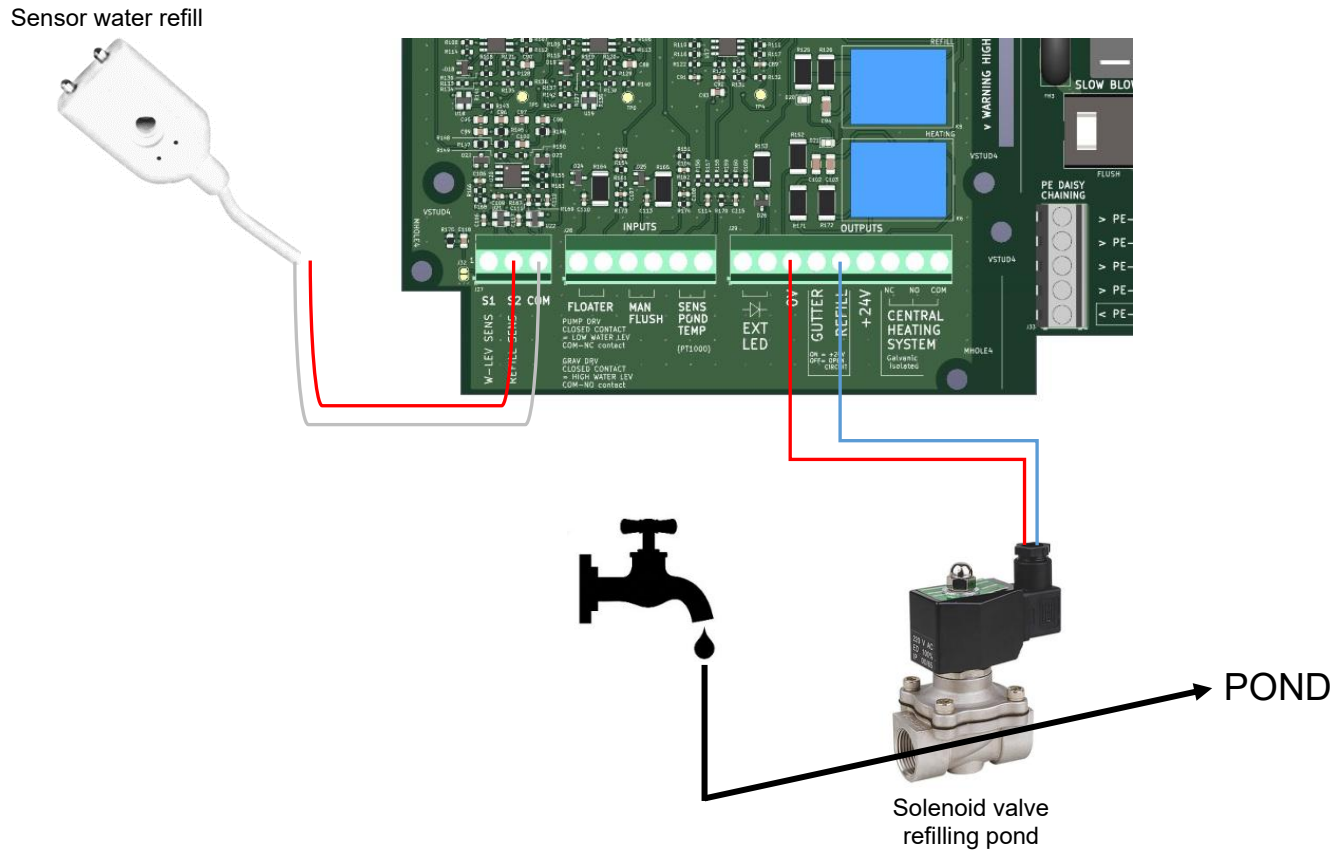

## 6 TROUBLESHOOTING

ISSUE	CAUSE	SOLUTION
Drum filter rinses to often	<ul style="list-style-type: none"> <li>- Screen clogged</li> <li>- Flow to high</li> <li>- Sensor position not correct</li> </ul>	<ul style="list-style-type: none"> <li>- Clean screen with citric acid, if heavily soiled, use screen cleaner</li> <li>- Regulate pond pump</li> <li>- Check sensor position (see chapters 3.3 and 4.3)</li> </ul>
Drum filter doesn't rinse automatically	<ul style="list-style-type: none"> <li>- Water level to low</li> <li>- Screen clogged</li> </ul>	<ul style="list-style-type: none"> <li>- Refill pond</li> <li>- Clean screen with citric acid, or screen cleaner</li> </ul>
Drum doesn't turn while rinsing	<ul style="list-style-type: none"> <li>- Motor broken</li> <li>- Motor overheated</li> <li>- Fuse broken</li> </ul>	<ul style="list-style-type: none"> <li>- Controleer motor door aan te sluiten op constante spanning (220V)</li> <li>- Let the engine cool down (approx. 60minutes)</li> <li>- Replace fuse (slow blow 6.3x32 2A)</li> </ul>
Drum keeps turning	<ul style="list-style-type: none"> <li>- Plug is in wrong socket</li> </ul>	<ul style="list-style-type: none"> <li>- Plug should be in socket "MOTOR DRUM FILTER"</li> </ul>
Cleaning pump doesn't work	<ul style="list-style-type: none"> <li>- Cleaning pump broken</li> <li>- Fuse broken</li> </ul>	<ul style="list-style-type: none"> <li>- Controleer spoelpomp door aan te sluiten op constante spanning (220V)</li> <li>- Replace fuse (slow blow 6.3x32 6A)</li> </ul>
Cleaning pump keeps running	<ul style="list-style-type: none"> <li>- Plug is in wrong socket</li> </ul>	<ul style="list-style-type: none"> <li>- Plug should be in socket "CLEANING PUMP"</li> </ul>
Circulation pump doesn't work	<ul style="list-style-type: none"> <li>- Sensor connector not plugged in</li> <li>- Fuse blown</li> </ul>	<ul style="list-style-type: none"> <li>- Plug the sensor connector into the control unit</li> <li>- Replace the fuse (slow-blow 6.3x32 8A)</li> </ul>

## 7 MAINTENANCE SCHEDULE

### WEEKLY

ELEMENT	CONTROL	ACTION
Gutter	Check that the waste water drain is not clogged	Visual inspection, manually remove any accumulated dirt
Spray nozzles	Check that the spray nozzles are not clogged	If dirty stripes are visible on the cloth, a spray nozzle is clogged. Loosen the union nut and clean the spray nozzle

### MONTHLY

ELEMENT	CONTROL	ACTION
Screen	Check that there are no holes or tears in the fabric	Visual inspection, replace any broken elements
Bypass covers for drum partition	Check that the plastic covers are intact	If these are broken, replace them: Art. 900.4081 (not UV-resistant) Art. 900.4082 (UV-resistant)
Screen	Once every three months	Clean the screen with citric acid or screen cleaner

### ANNUAL

ELEMENT	CONTROL	ACTION
Drum seal	Check whether the silicone rubber is still flexible	If the seal is no longer flexible, it must be replaced: Art. 400.2000 drum ECO/**22/**35 Art. 400.2001 drum **50/65/100N/140N Art. 400.2002 drum PP100 Art. 400.2003 drum ENTRY